

Mecmesin

testing to perfection

Orbis

closure torque tester

Operating Manual



Contents

The Orbis

Assembly of the Orbis	3
Powering the Orbis	4
Using the Orbis	5
Optional Settings	10
RS232 Commands	13
Dimensions	16
Orbis Specifications	18

The Orbis

Introduction

Thank you for choosing Mecmesin's Orbis Digital Torque Tester. With correct use and regular re-calibration it will give many years of accurate and reliable service.

The Orbis has been specifically designed as a high-accuracy, portable instrument for measuring clockwise and counter-clockwise torques. Using the latest integrated circuit technology and intuitive programming, the Orbis is easy to use by all operators.

Before Use

Upon receiving the unit please check that no physical damage has occurred to the packaging material, plastic case or the instrument itself. If any damage is evident please notify Mecmesin immediately.

Operation

The most commonly used features such as displaying torque, peak hold, zero and changing of displayed units can all be done by pressing single dedicated keys on the front panel.

For less frequently used features a number of 'hot keys' are provided, whereby the operator simply presses and holds an appropriate key upon startup to enable a gauge option.

Assembly of the Orbis

When Orbis is in transit, the top plate is removed to avoid damage to the torque sensor.

Fitting Instructions for the Orbis Top Plate

Step 1. Orbis with torque drive shown



Step 2. Align top plate with torque drive. The handle is positioned to the left.



Step 3. Tighten screws hand-tight only.



Step 4. For use of Orbis with handle at front, repeat steps 1 to 3 but position top plate accordingly during step 2.

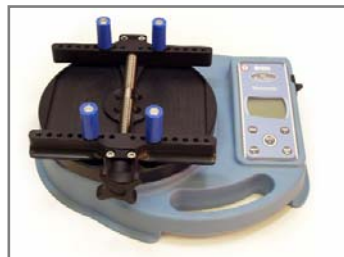

Powering the Orbis

The Orbis features an internal rechargeable battery pack, which is supplied fully charged to allow use straight from the box.

Recharging the Orbis

To recharge the Orbis, remove the rubber cap from the charger socket on the right side panel of the case, and connect the mains adaptor/charger to the socket. To achieve full charge, it is suggested the mains power remains connected for 14 - 16 hours.

Mains operation

The Orbis may also be powered directly from the mains. Simply maintain the mains adaptor/charger connection to your mains supply as above. Only use the adaptor/charger supplied.

Using the Orbis

Fitting accessories

The Orbis is supplied with 4 pegs which grip the sample during testing.

Screw the pegs into the runners on the top fixture equally spaced to ensure the sample is securely gripped when the runners are brought together using the star handle on the end of the lead screws.

Ensure that the pillars are finger tight and the sample securely clamped, otherwise rotation in the fixture will occur during testing.

Powering up

As shown in Fig. 1, the control panel has 6 keys:-

Fig.1



To power up the Orbis press the red ① key. A short self test runs during which the display will show the capacity in 'N.m' (newton metres).



After the self test, providing no torque has been applied to the instrument, the display will show all zeros. This is because the Orbis re-zeros itself during the self test routine.

If a torque is applied rotationally via the fixture, the reading on the display will register the applied torque.

* **Do not overload** the torque sensor, as this could cause irreparable damage.

Loads greater than 120% of full-scale will produce an audible beep until load is released and an OL symbol will appear on the display **for 30 seconds**.

Loads greater than 150% of full-scale will produce an audible beep until load is released and an OL symbol will appear **permanently** on the display. Consult your supplier to arrange repair.

To power down the Orbis press the red  key.

Clockwise and Counter-clockwise Values

If the Orbis has suffered a serious overload condition, the torque indicator bar will be partially displayed even when no torque is present. This is a warning that the torque sensor is damaged and you should immediately contact your supplier to arrange repair.

Clockwise torque is displayed on the Orbis and recognised by the symbol shown in Fig. 2.

Counter-clockwise torque is displayed on the Orbis and recognised by the symbol shown in Fig. 3c.

Fig. 2

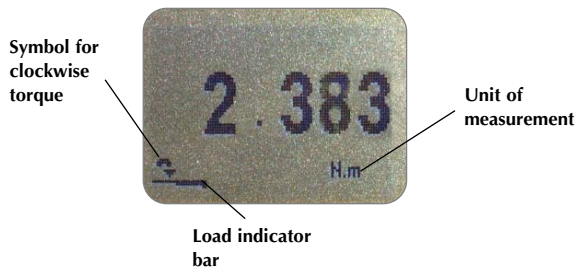

A torque indicator bar alerts the operator to how much load has been applied to the torque sensor. As the load approaches the maximum rating of the torque sensor, the indicator bar changes appearance when above approximately 80% of the rated capacity. This warns the operator that steps should be taken to prevent excessive torque being applied.

When applying clockwise torque, the indicator bar begins solid in appearance, then becomes striped when the capacity is approached. When applying counter-clockwise torque, the indicator bar begins striped, then becomes solid.

– see Fig. 3b & 3c.

Zeroing the Orbis

During operation of the Orbis, it is sometimes necessary to zero the display – e.g. when you wish to tare out a displayed torque applied by the sample, so it does not become part of the measured reading. Press and release the **ZERO** key. The display will freeze whilst the key is pressed.

Changing the unit of measurement

You can choose from the following units of measurement: N.m, N.cm, mN.m, gf.cm, kgf.cm, kgf.m, lbf.ft, lbf.in, ozf.in.

To change the displayed units, press and release the **UNITS** key. Each successive key press will select the next available units until the Orbis returns to its original setting. The Orbis automatically converts readings as new units of measurement are selected.

Max (peak) readings

The Orbis detects and stores maximum (peak) torque in both clockwise and counter-clockwise directions.

'Max' mode

Press the **MAX** key. The display will show the word **MAX** together with the highest counter-clockwise torque and the highest clockwise torque detected during the test. The current load being applied to the torque sensor is also displayed. - see Fig. 3a

Dual Max

Fig. 3a



Max Clockwise Torque

Press the **MAX** key again, and the display will show the maximum clockwise torque identified by its symbol.

Fig. 3b



Max Counter-clockwise Torque

Press the **MAX** key again, and the display will show the maximum counter-clockwise torque identified by its symbol.

Fig. 3c

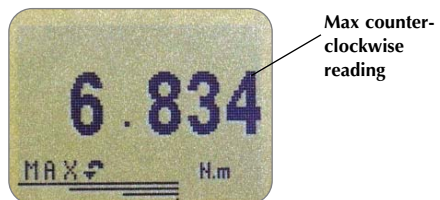

'Normal' mode

Press the **MAX** key again, and the word **MAX** has now disappeared from the display. The display will now indicate torque of either direction, as it is applied, maintaining a 'running' display.

Press the **RESET** key to clear both maximum registers and prepare for detecting the next maximum readings.

Data Output

Orbis uses 9600 Baud 8 data bits, 1 start bit 1 stop bit and no parity.

A full range of data cables are available to connect the Orbis to peripheral devices. Please contact your supplier for further information.

The Orbis has RS232, Digimatic and analogue output signals. It is possible to transmit the displayed reading to peripheral devices (e.g. PC, printer) by pressing and releasing the **TXD** key.

Displayed readings can also be requested individually from a PC via the RS232 interface by sending a "?" character. See page 13. When using the Orbis for creating a graphical presentation of data, ensure that the normal mode, and not a max mode, is selected.

For sending a continuous data stream to a PC, press and hold the **TXD** key for 2 seconds. TX will now appear in the display to indicate that data is being sent. To stop sending data, simply press and release the **TXD** key, at which point TX will disappear from the display.

Please note that the continuous data stream only starts when approximately 2% of the rated capacity of the Orbis is reached.

Optional Settings - 'Hot Keys'

Backlit Display

It is possible to activate a back-light on the Orbis display. Press and hold **RESET** whilst powering up the Orbis with the  key. The back-light is now operating.

Please note that battery consumption is doubled when using the back-light.

Auto-off

To conserve battery power, it is possible to activate an Auto-off function. This causes the Orbis to power down automatically 5 minutes after the last key press, or 5 minutes after the last application of a torque greater than 2% of full capacity.

Press and hold **ZERO** whilst powering up the Orbis with the  key. The symbol 'Ao' will appear in the display to indicate Auto-off is active.

Invert Display

It may be desirable to invert the display, so that it may be easily read upside down. By pressing and holding **MAX** whilst powering up the Orbis with the  key, the display is inverted.

Locking and unlocking 'Max' mode

Once the desired Max display mode has been selected, it is possible to lock the mode, so that further pressing the **MAX** key results in no change.

Press and hold **RESET** and **MAX** keys simultaneously whilst powering up the Orbis with the  key. 'MAX KEY LOCKED' will appear on the display until the 'Hot Keys' are released. The Max display mode is now locked.

To unlock the Max display mode, repeat as above. 'MAX KEY UNLOCKED' will appear on the display until the 'Hot Keys' are released.

Locking and unlocking the unit of measurement

Once the desired unit of measurement has been selected, it is possible to lock the units, so that further pressing the **UNITS** key results in no change.

Press and hold **RESET** and **UNITS** keys simultaneously whilst powering up the Orbis with the  key. 'UNITS KEY LOCKED' will appear on the display until the 'Hot Keys' are released. The units are now locked.

To unlock the units, repeat as above. 'UNITS KEY UNLOCKED' will appear on the display until the 'Hot Keys' are released.

Removal of minus sign for counter-clockwise (release torque) measurements

To differentiate between clockwise and counter-clockwise measurements when transmitted to peripheral devices, counter-clockwise results may be prefixed with a minus sign. Press and hold the **TXD** key whilst powering up the Orbis with the  key. The display will show TX SIGN OFF and ON. This will transmit a negative sign for counter-clockwise readings if set to ON.

Use the **TXD** key to position the arrow cursor against the desired selection and press the **RESET** key. The display will continue to the main menu.

Torque Sensor Diagnostic test

An instrument showing an overload condition cannot be relied upon to provide accurate, repeatable measurement – please consult your supplier.

If you suspect that your torque sensor has sustained an overload, it is possible to check the status of the torque sensor immediately.

Symptoms of overload may be (a) OL in display (b) buzzer sound (c) torque indicator bar present even under zero load.

Place the Orbis horizontally on a flat, level surface. Press and hold the **UNITS** key whilst powering up the Orbis with the  key.

The torque sensor diagnostic test screen will appear on the display, as shown in Fig. 4.

Fig. 4



The offset value provides an indication of the condition of the torque sensor, and is defined as the % difference between the critical zero and the current reading.

If the offset is between 5 - 10 %, please contact your supplier to arrange a re-calibration of your Orbis.

If the offset is greater than 10 %, please contact your supplier to arrange for a torque sensor replacement.

These values are given as an indicator only – the need for calibration/repair may vary according to the individual characteristics of the torque sensor.

In addition to the offset, the number of overloads (OL) experienced by the torque sensor in both clockwise and counter-clockwise directions are displayed. An overload is registered when a torque exceeding 150% of the rated capacity of the torque sensor is applied in either direction.

To exit the torque sensor diagnostic test screen, press **MAX**.

RS232 Commands Table: Configuration

It is possible to remotely configure the setting of your Orbis by sending the following RS232 command characters:

Character in ASCII	Decimal	Hexadecimal	Function
M	77	0x4D	Current mode
U	85	0x55	Current units
C	67	0x43	Torque sensor capacity
@	64	0x40	Configuration status request
*	42	0x2A	Continuous transmit
r	114	0x72	Normal Screen
s	115	0x73	Dual Max
t	116	0x74	Max Clockwise
u	117	0x75	Max Counter-clockwise
a	97	0x61	N.m
b	98	0x62	N.cm
c	99	0x63	mN.m
d	100	0x64	gf.cm
e	101	0x65	kgf.cm
f	102	0x66	kgf.m
g	103	0x67	ozf.in
h	104	0x68	lbf.ft
i	105	0x69	lbf.in
?	63	0x3F	Transmit the current reading
CTRL a	1	0x01	TXD key
CTRL b	2	0x02	UNITS key
CTRL c	3	0x03	MAX key
CTRL d	4	0x04	RESET key
CTRL e	5	0x05	ZERO key

RS232 Command Responses: Information

It is possible to remotely interrogate your Orbis by sending the following RS232 commands. This will inform you which settings are currently configured.

Command: M

Response	Orbis Display Mode
Normal	Normal Mode
MaxC	Max Counter-clockwise
MaxT	Max Clockwise
MaxDual	Dual Max Screen

Command: U

Response for Torque Sensor
N.m
N.cm
mN.m
gf.cm
kgf.cm
kgf.m
lbf.ft
lbf.in
ozf.in

Command: C

The torque sensor size, in the current selected units.

Note: 'xxxx' will be transmitted if the torque sensor is not calibrated or has a serious fault. Contact Mecmesin or your supplier.

Command: @

When all options are OFF, and the Orbis is set at defaults, you will receive the following information listing:

Response	Explanation of Response
ORBIS	Gauge type
6N.m	Torque sensor size in N.m as per transmitting 'C'
V01	Version number
Normal	Mode of operation as per transmitting 'M'
N	Units of operation as per transmitting 'U'

Function	Default Setting
TXD -SIGN	OFF
BACKLIGHT	OFF
AUTO-OFF	OFF
INVERT	OFF

TXD-SIGN 1 options explained below;

TXD-SIGN 1	
1	Transmit minus sign, ON or OFF

BACKLIGHT 1 options explained below;

BACKLIGHT 1	
1	Backlight enabled, ON or OFF

AUTO-OFF 1 options explained below;

AUTO-OFF 1	
1	Auto-off time, OFF or 5 mins

INVERT 1 options explained below;

INVERT 1	
1	Display inverted, ON or OFF

DIMENSIONS

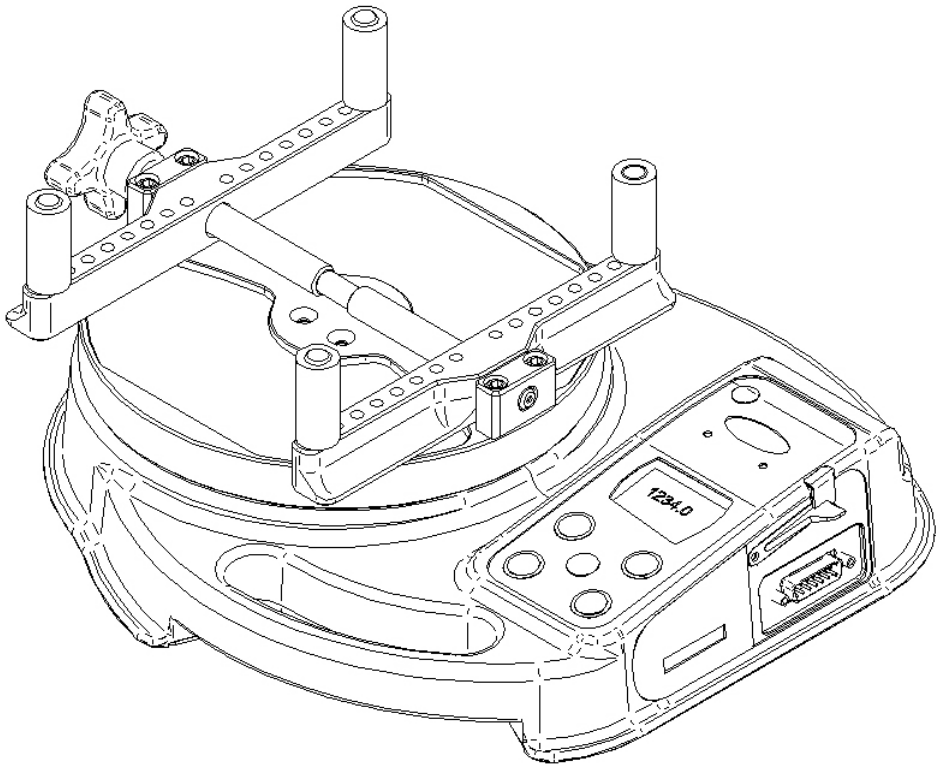

Side view

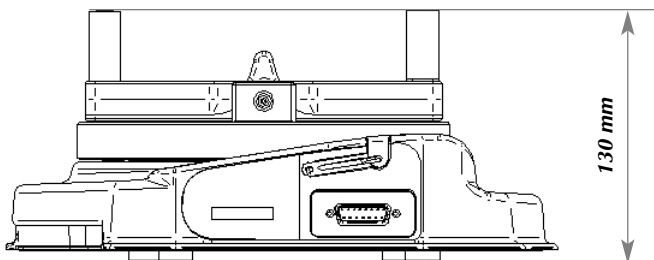

Top view

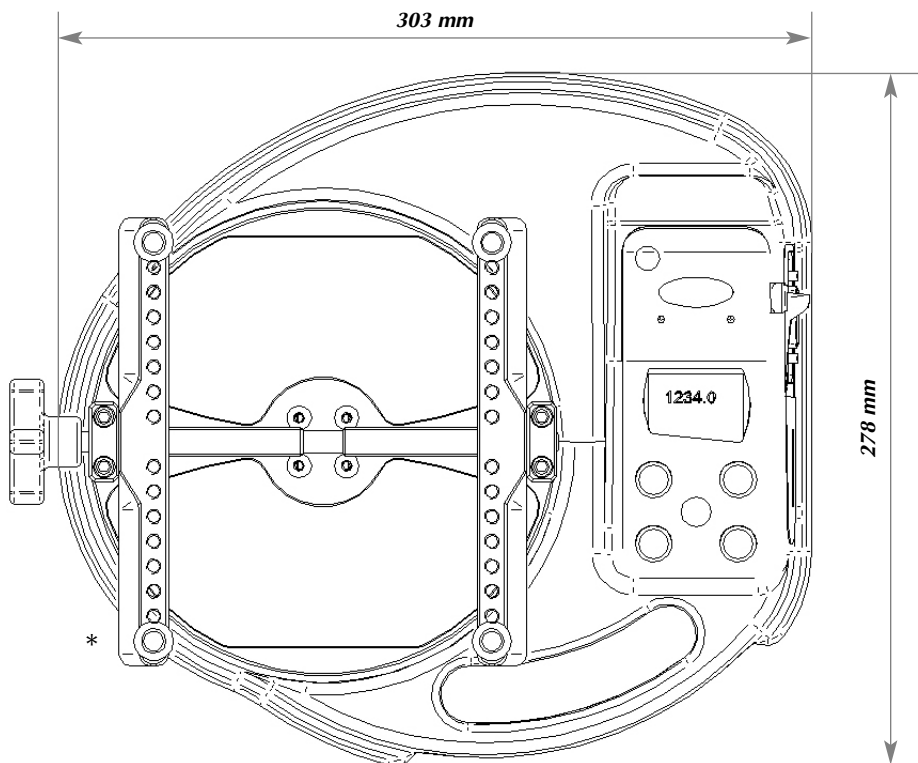

* Min-Max opening: 10 - 190 mm diameter

ORBIS SPECIFICATIONS

RANGE & UNITS OF MEASUREMENT

Ranges:- 0 - 6N.m, 0 - 60kgf.cm, 0 - 53lbf.in

Units:- N.m, N.cm, mN.m, gf.cm, kgf.cm, kgf.m, lbf.ft, lbf.in, ozf.in

ACCURACY

± 0.5% of full scale

Calibration temperature: 20°C ± 2°C

Operating temperature: 10°C - 35°C

Temperature shift at zero load: ± 0.01% of full-scale/°C

OUTPUT

- RS232-C 9600 band rate, 8 data bits, 1 Start bit, 1 Stop bit, no parity
- Digimatic Format
- Analogue 0V at zero load,
approximately ±1.5V uncalibrated
for full-scale clockwise/counter-clockwise

ADAPTOR / CHARGER UNIT

The mains adaptor/charger supplied with the Orbis is a constant-current type.

Primary: 230V – 50Hz (110V – 60Hz version also available)

Secondary: 100mA constant current at 9V

Charger output plug: Centre = positive Outer = negative

WATER RESISTANCE

The Orbis is rated to IP54 water resistance.

Note: This IP rating is only valid when no charger or comms cables are connected, and the charger socket cap and comms connector cover are in place.

Communications Cables

Interface cables for connecting your Orbis to peripheral devices:

Cable	Mecmesin Part Number
Orbis to RS232 (9-pin D-type)	351-054
RS232 (9-pin D-type) to USB converter kit	432-228
Orbis to Digimatic (Mitutoyo 10-way IDC)	351-055
Orbis to Analogue	351-057

Allocation for the pins on the female 15 way 'D Type' Communication Connector:

Pin Out:	
1	Analogue Output
2	RS232 Transmit
3	RS232 Receive
4	Digimatic Clock Output
5	Digimatic Ready Output
6	not used
7	not used
8	not used
9	not available
10	Ground
11	Digimatic Request Input
12	Digimatic Data Output
13	not used
14	not used
15	not used

Also Available from Mecmesin...

Tornado

The Tornado is a sophisticated digital torque tester featuring all of the functions of the Orbis, but with a broad array of useful advanced capabilities, including;

- Tamper-evident closure testing facility; capture both 'slip' & 'bridge' peak torques.
- Choice of 4 models; 1.5N.m, 3N.m, 6N.m & 10N.m capacity
- Tolerance alerting with audible & LED pass/fail alarms
- On board memory of up to 500 readings

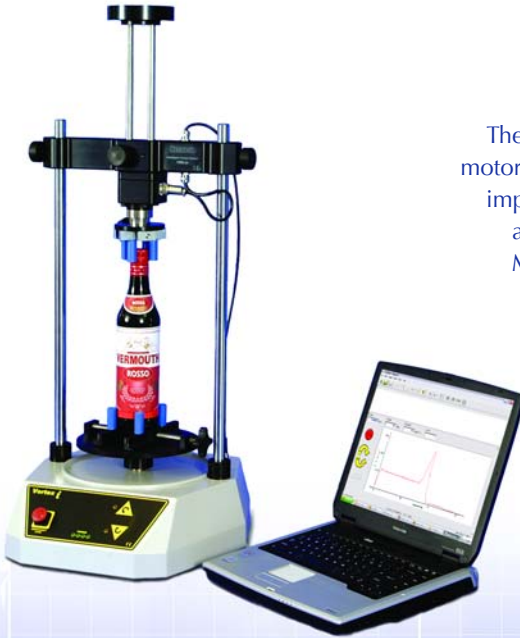

Vortex-i

The Vortex-*i* is a fully computer-controlled motorised torque testing system. The Vortex-*i* improves reproducibility, eliminating error arising from manual torque application. Mecmesin's powerful, flexible and user-friendly Emperor™ software enables fully computerised control of the test procedure, analysis and reporting.

To find out about our broad range of grips and accessories, please call us on +44 (0) 1403 799979, or visit us at www.mecmesin.com.

MultiTest-x

The MultiTest-x range of force testing systems are ideal for quality control applications in a production environment. An integrated console controller enables routine test programs to be set up using basic machine control parameters. Available in a range of configurations, from single-column machines to advanced twin-column test frames, with a range of loadcell capacities on offer. Features include;

- Display of peak load, ave. load or load at predefined time/displacement
- Cycle testing function
- 5 models; 1kN, 2.5kN, 5kN, 10kN and 25kN capacity
- Bi-directional interface for data transfer

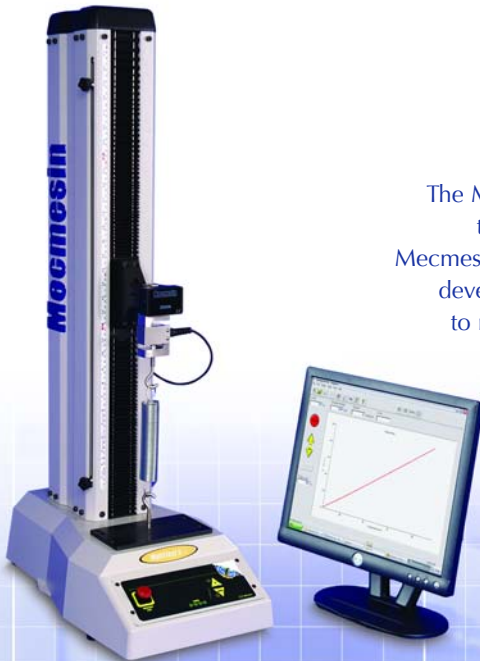

MultiTest-i

The MultiTest-i is a fully computer-controlled tension and compression testing system. Mecmesin's Emperor™ software enables users to develop sophisticated routines and analyses to meet precise requirements for advanced testing applications. 5 models are available with 1kN, 2.5kN, 5kN, 10kN or 25kN capacity.

Mecmesin

testing to perfection

Over 25 years experience in force & torque technology

Formed in 1977, Mecmesin Ltd is today widely regarded as a leader in force and torque technology for quality control testing in design and production. The Mecmesin brand stands for excellent levels of performance and reliability, guaranteeing high quality results. Quality control managers, designers and engineers working on production lines and in research laboratories worldwide rely upon Mecmesin force & torque measurement systems for a range of quality control testing applications, which is almost limitless.

Visit us on the web at
www.mecmesin.com

Head Office

Mecmesin Limited

Newton House, Spring
Copee Business Park,
Slinfold, West Sussex,
RH13 0SZ, United Kingdom,
e. sales@mecmesin.com
t. +44 (0) 1403 799979
f. +44 (0) 1403 799975

North America

Mecmesin Corporation

45921 Maries Road,
Suite 120, Sterling
Virginia 20166, U.S.A.
e. info@mecmesincorp.com
t. +1 703 433 9247
f. +1 703 444 9860

Asia

Mecmesin Asia Co. Ltd

9/1 Chaiyo Building, 11th Floor,
Room 1106, Rama 9 Road, Huaykwang,
Bangkok, 10310, Thailand
e. sales@mecmesinasia.com
t. +66 2 247 46 81
f. +66 2 247 46 82

China

Mecmesin (Shanghai) Pte Ltd

Unit 18D, SiChuang Building No3,
No 600, Tian Shan Road,
Changning District,
Shanghai, People's Republic of China
e. sales@mecmesin-china.com
t. +86 21 6233 3459
f. +86 21 6233 3479



ISO 9001 FS 58553

431-262

S.I. Instruments
256 South Rd. Hilton
South Australia 5033
Ph (08) 8352 5511

info@si-instruments.com
www.si-instruments.com